

SWIFTYWELL CALC KILLER

US Patent No. 11,422,068



#1	DESCRIPTION		
5M	Thermowells - Add a W here for a Brass plug and stainless steel chain attached to well (Example: 5MW)		
#2	SHANK STYLE [15]		
A S T	Step Straight Tapered (Standard)	X	Other, specify

Note: Standard sensor connections are 1/2" FNPSM (female straight) to match 1/2" MNPT (male tapered)

#3	BORE SIZE & INSTRUMENT CONNECTION (I.C.)
2	.260" ID used for .250" OD sensors (Standard)
3	.385" ID used for .375" OD sensors (straight or tapered shank style only)
X	Other, specify

NOTE: Add N suffix for FNPT.(Example: 2N = .260" ID with 1/2" FNPT sensor connection)

#4	L (UNSUPPORTED LENGTH)	Length Calculation Example:		
L__"	Length in inches	L	H	T
#5	H (NOZZLE HEIGHT)	3"	6"	0"
H__"	Length in inches	Spring loaded sensor length		
#6	T (LAG) EXTENSION	12"		
T__"	Length in inches	Notes:		
Z	N/A (Standard)	- See matching sensor length formulas below		
		- U length is equal to L+H		

[] Brackets indicate page numbers where additional helpful information can be found in section 5 of technical catalog. Now available online at www.JMS-SE.com/TechnicalCatalog

#7	WELL MATERIAL [31-34]		
G	Carbon steel A105	A	Alloy 800H/HT
H	304 stainless steel	P	Hastelloy B-3
I	Low Carbon 304 stainless steel	Q	Hastelloy C-276
J	310 stainless steel	S	Titanium
K	316 stainless steel	Y	Carbon steel 1018
L	Low Carbon 316 stainless steel	X*	Other, specify
M	Inconel 600		
N	Monel 400		

*For more options and unique material requirements, consult your sales representative directly.

#8	SIZE OF FLANGE		
3	1"	6	3"
4	1 1/2"	X	Other, specify
5	2"		

#9	FLANGE PRESSURE RATING (PSI)			
A	150	E	900	per ASME B-16.5
B	300	F	1500	
C	400	G	2500	
D	600	X	Other, specify	

#10	LAPPING FLANGE MATERIAL
Z	N/A (Customer supplied)
G	Carbon Steel A105 (Standard)
K	316 SS
X	Other, Specify

#11	SWIFT-O-LET STYLE
B	Butt weld (Standard)
S	Socket weld

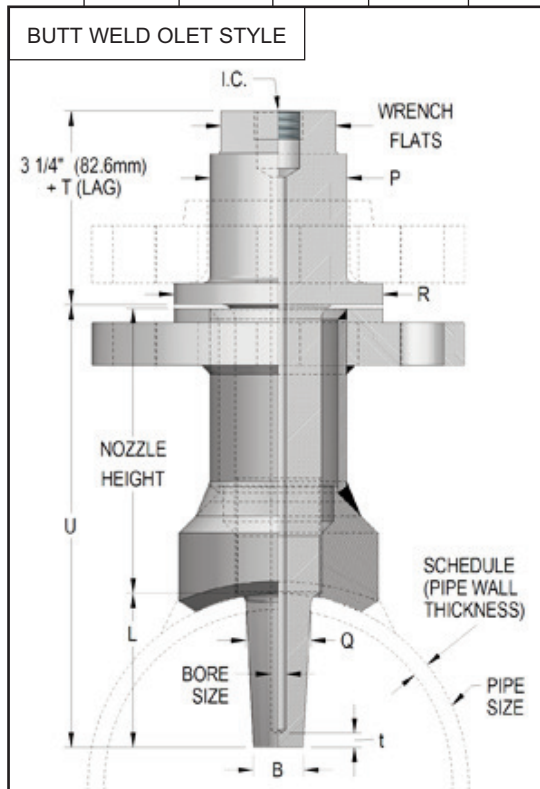

Matching sensor lengths:
 -All Spring-loaded designs and all Compression designs with a nipple/union extension
 $L(\#4) + H(\#5) + T(\#6) + 3"$
 -All Welded designs
 $L(\#4) + H(\#5) + T(\#6) + 2 1/4"$
 -All Compression designs without a nipple/union extension
 $L(\#4) + H(\#5) + T(\#6) + 5 1/4"$

5M	T	2	L3	H6"	Z	K	5	D	G	B
----	---	---	----	-----	---	---	---	---	---	---

SWIFTWELL CALC KILLER US Patent No. 11,422,068

#12	SWIFT-O-LET NOZZLE & RECEIVING FLANGE MATERIAL			 <p style="text-align: center;">JMS SOUTHEAST INCORPORATED JMS-SE.COM</p>
G H I J K L M N	Carbon steel A105 304 stainless steel Low Carbon 304 stainless steel 310 stainless steel 316 stainless steel Low Carbon 316 stainless steel Inconel 600 Monel 400	A P Q S Y X*	Alloy 800H/HT Hastelloy B-3 Hastelloy C-276 Titanium Carbon steel 1018 Other, specify	
*For more options and unique material requirements, consult your sales representative directly.				Note: JMS recommends matching Customer's process pipe material to avoid dissimilar metal welds.
#13	SWIFT-O-LET FITTING # RATING			
L M N X	3000# 6000# 9000# Other, specify			
#14	CUSTOMER PIPE SIZE (DETERMINES OLET SADDLE RADIUS)			
P ___" D ___"	Nominal pipe size (inches) Pipe diameter (inches)			
#15	DESIRED COMPONENTS (Choose all that apply)			
C W Z	SwiftWell + Lapping Flange + Unwelded Nozzle Components SwiftWell + Lapping Flange + Welded Nozzle Components SwiftWell Only			
				Note: If W is selected, Customer must specify any special welding testing & documentation requirements.

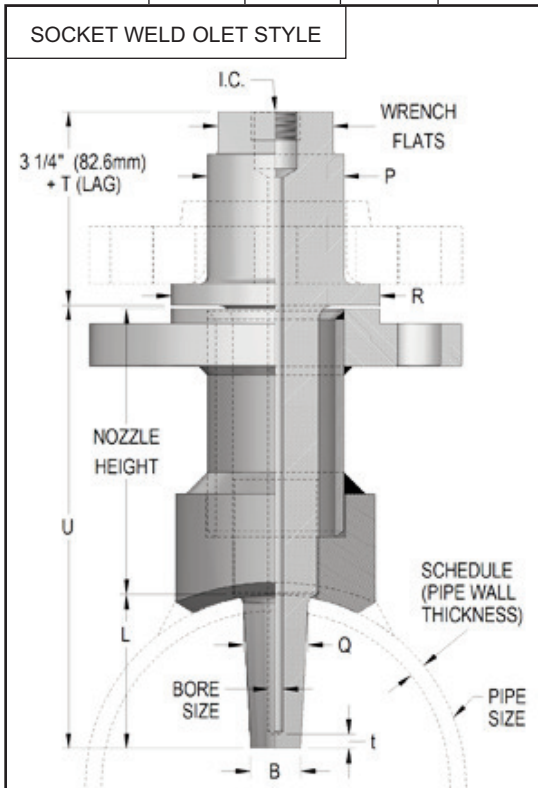

Van Stone Dimensions Chart			
Flange Size	P (Stem Ø)	R (Sealing Face Ø)	Flange Bore
1"	1.315"	2.000"	1.375"
1 1/2"	1.900"	2.875"	1.970"
2"	2.375"	3.625"	2.460"

- Matching sensor lengths:**
- All Spring-loaded designs and all Compression designs with a nipple/union extension
 $L(\#4) + H(\#5) + T(\#6) + 3"$
 - All Welded designs
 $L(\#4) + H(\#5) + T(\#6) + 2\ 1/4"$
 - All Compression designs without a nipple/union extension
 $L(\#4) + H(\#5) + T(\#6) + 5\ 1/4"$

