

# THREADED, WELD-IN, & SOCKET WELD THERMOWELLS

**\*NEW\* FREE** Wake Frequency Calculations to ASME PTC 19.3 TW, **SwiftyCalc!**

Visit [JMS-SE.COM](http://JMS-SE.COM) to sign up today! [www.jms-se.com/SwiftyCalc](http://www.jms-se.com/SwiftyCalc)

#1	DESCRIPTION [See pgs 20-24 for complete information on dimensions, velocity ratings, and pressure ratings]				
5	Thermowells - Add "W" here for a plug with a chain attached to well. (i.e. 5W)				
#2	THREADED WELLS External Thread	SOCKET WELL Nominal Size    Actual OD		WELD IN Well Size	
1	1/2" NPT	N/A	N/A	N/A	
2	3/4" NPT (Standard)	3/4" pipe	1.050"Ø (Standard)	.75"Ø	
3	1" NPT	1" pipe	1.315"Ø	1.00"Ø	
4	1-1/2" NPT	1-1/2" pipe	1.900"Ø	1.50"Ø (Standard)	
5	1-1/4" NPT	1-1/4" pipe	1.660"Ø	1.25"Ø	
X	Other, specify	-	-	-	
#3	SHANK STYLE [15]				
A	Step shank (Standard)				
S	Straight shank				
T	Tapered shank				
B*	Built up (Recommended for over 40" overall length, see drawing on 5-2)				
X	Other, specify				
#4	THREADED OR SOCKET WELD WELLS				
T	Threaded well design		W	Weld-In (Tapered shank standard)	
S	Socket weld well design		X	Other, specify	
#5	BORE SIZE & SENSOR CONNECTION Standard is NPSM.				
2	.260" ID used for .250" OD sensors (Standard)		Add "N" for FNPT. (Ex: 2N = .260" bore, 1/2" FNPT sensor conn.) See drawing.		
3	.385" ID used for .375" OD sensors (straight or tapered only)				
X	Other, specify				
#6	U (INSERTION) DEPTH [15]	STANDARD "T" DIMENSION	SENSOR LENGTH		
B	2-1/2"	JMS recommends the use of the "Built Up" design if longer than 40" overall length. See page 5-2 for drawing.	2	4	6
C	4-1/2"		3	6	9
D	6"		3	7-1/2	10-1/2
E	7-1/2"		3	9	12
F	10-1/2"		3	12	15
G	13-1/2"		3	15	18
H	16-1/2"		3	18	21
I	22-1/2"		3	24	27
X	Other, specify				
#7	T (LAG) EXTENSION [15]				
T	Standard lag (For length see Table in Symbol #6)				
Z	N/A (No lag)				
X	Other, specify				
#8	WELL MATERIAL [31-34]				
A	Alloy 800H/HT	M	Inconel 600		
B	F5	N	Monel 400		
C	F9	Q	Hastelloy C-276		
D	F91	S	Titanium		
E	F22	X	Other, specify (Teflon, PVC, Nickel, etc.)		
F	F11				
G	Carbon steel				
H	304 Stainless steel				
I	Low Carbon 304 Stainless steel				
J	310 Stainless steel				
K	316 Stainless steel (Standard)				
L	Low Carbon 316 Stainless steel				
#9	TAGGING OPTIONS				
1	Stamped on well (Standard)				
X	Other, specify				
M	MTR				
W	Premium SwiftyCalc ASME 19.3TW Calculation				
	<b>Note: You must always specify information required on tag.</b>				

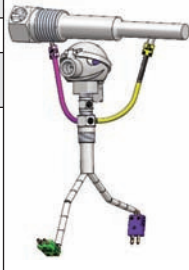

Note: See drawing below and pg 5-2.

Note: Standard sensor connections are 1/2" FNPSM (female straight) to match 1/2" MNPT (male tapered) per ASME B40.200-2008 (B40.9)

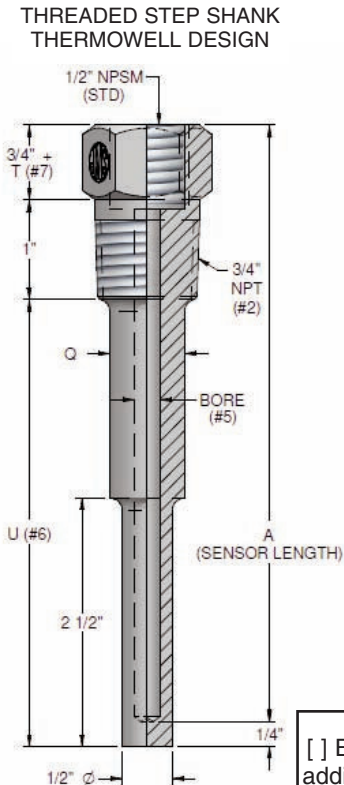

[ ] Brackets indicate page numbers where additional helpful information can be found in technical catalog. Now available online at [www.JMS-SE.com/TechnicalCatalog](http://www.JMS-SE.com/TechnicalCatalog)

5 2 A T 2 E T H 1

# THREADED, SOCKET & WELD-IN THERMOWELLS

**\*NEW\* FREE** Wake Frequency Calculations to ASME PTC 19.3 TW, **SwiftyCalc!**  
 Visit [JMS-SE.COM](http://JMS-SE.COM) to sign up today! [www.jms-se.com/SwiftyCalc](http://www.jms-se.com/SwiftyCalc)

(JMS Southeast, Inc. participated in the ASME 19.3 committee performing the first major revision since 1974 to the only US thermowell strength standard. The new ASME PTC 19.3 TW standard addresses wake frequency calculations)

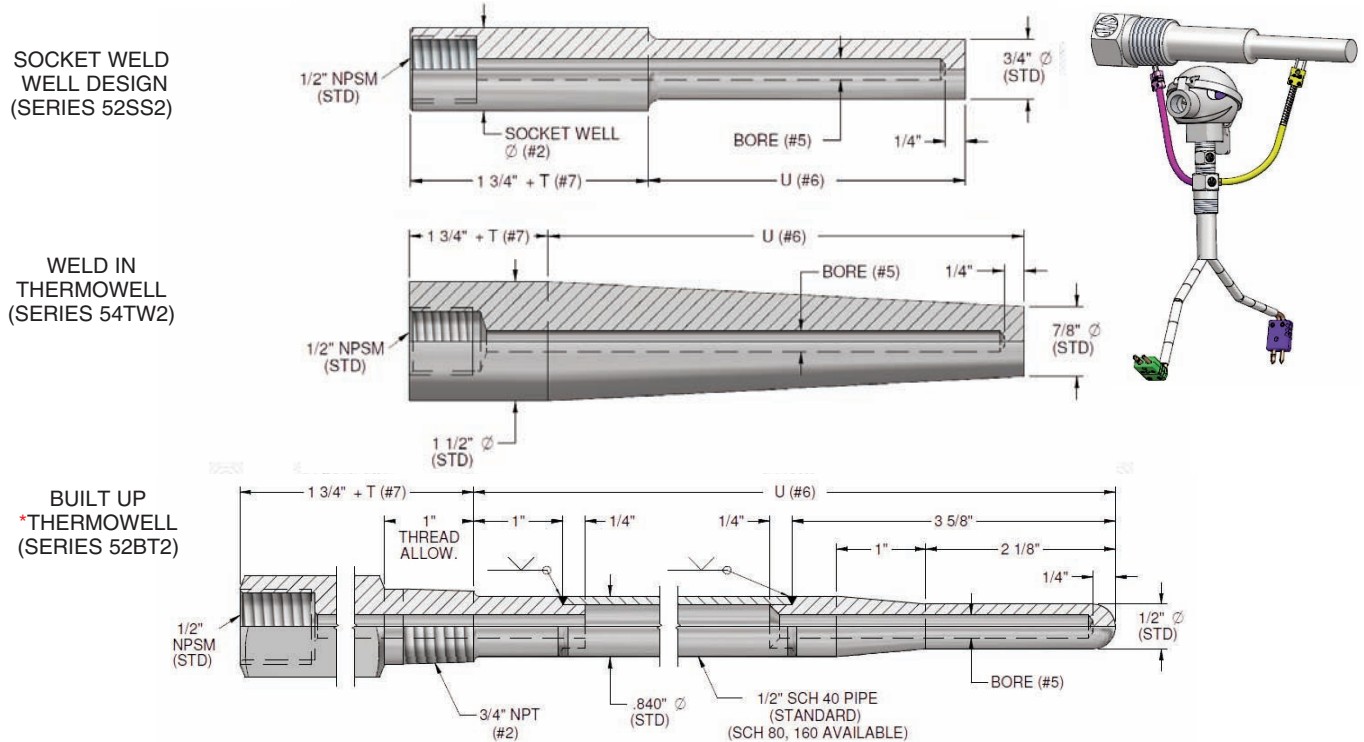

\* Built-Up design does not meet ASME PTC 19.3 TW specifications.

## LIMITED SPACE THERMOWELLS

#1	DESCRIPTION	
5L	Limited Space Thermowells - Add "W" here for a brass plug with a SS chain attached to well (Ex: 5LW)	
#2	WELL MATERIAL	
H	304 Stainless steel	
K	316 Stainless steel	
M	Inconel 600	
X	Other, specify	
#3	TAGGING OPTIONS	
1	Stamped on well (Standard)	
X	Other	
M	MTR	
<b>Note:</b> You must always specify information required on tag		
5L	M	1

**Note:** Immersion length of a spring-loaded sensor to fit this well is 2-5/8".

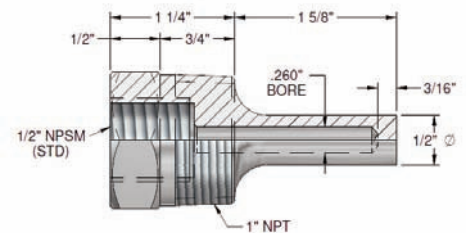

LIMITED SPACE THERMOWELL